

® **SERIE GARD**
ROAD BARRIER



G12000

Documentazione
Tecnica
56
rev. 2.0
03/2001
© CAME
CANCELLI
AUTOMATICI
119G56-GB



GENERAL CHARACTERISTICS

Description:

- Motorised barrier for control of passages with width of up to 12 m.
- Designed and built entirely by CAME S.p.A., meets UNI 8612 safety standards, with IP54 degree of protection.
- Guaranteed 12 months, unless tampered with.

Models:

G12000

Barrier with double, non-reversible 24 V DC gear motor. Galvanised steel housing with painted finish.

Accessories supplied:

G0121

- Aluminium barrier bar composed of:
 - Ø120 mm tube with L=6200 mm
 - Ø100 mm tube with L=6000 mm.
- Hardware and accessories for mounting the barrier bar.
- Fixed support for the barrier.

Optional accessories:

LB35

Circuit card for installation of an emergency battery.

G0461

Package of red phosphorescent strips for the barrier bar.

Important: For easy installation and maintenance, be sure to use CAME original control equipment, safety systems and accessories.

TECHNICAL CHARACTERISTIC

| PRODUCT VERSION | VOLTAGE REQUIREMENT | CURRENT DRAW | TOTAL MOTOR POWER RATING | DUTY CYCLE | REDUCTION RATIO | TORQUE | DURATION OF OPENING CYCLE | WEIGHT |
|-----------------|-------------------------|--------------|--------------------------|------------|-----------------|--------|---------------------------|----------|
| 1.0 | 230 V A.C. 24 V D.C. | 15 A max | 300 W | 50 % | 1/202 | 600 Nm | 10 s | 783 kg * |

(* Weight of G12000 barrier structure = 250 Kg / Weight of counterweight plates = 500 Kg / Weight of G0121 bar = 33 Kg)

CENTRE LINES AND EXTERNAL DIMENSIONS

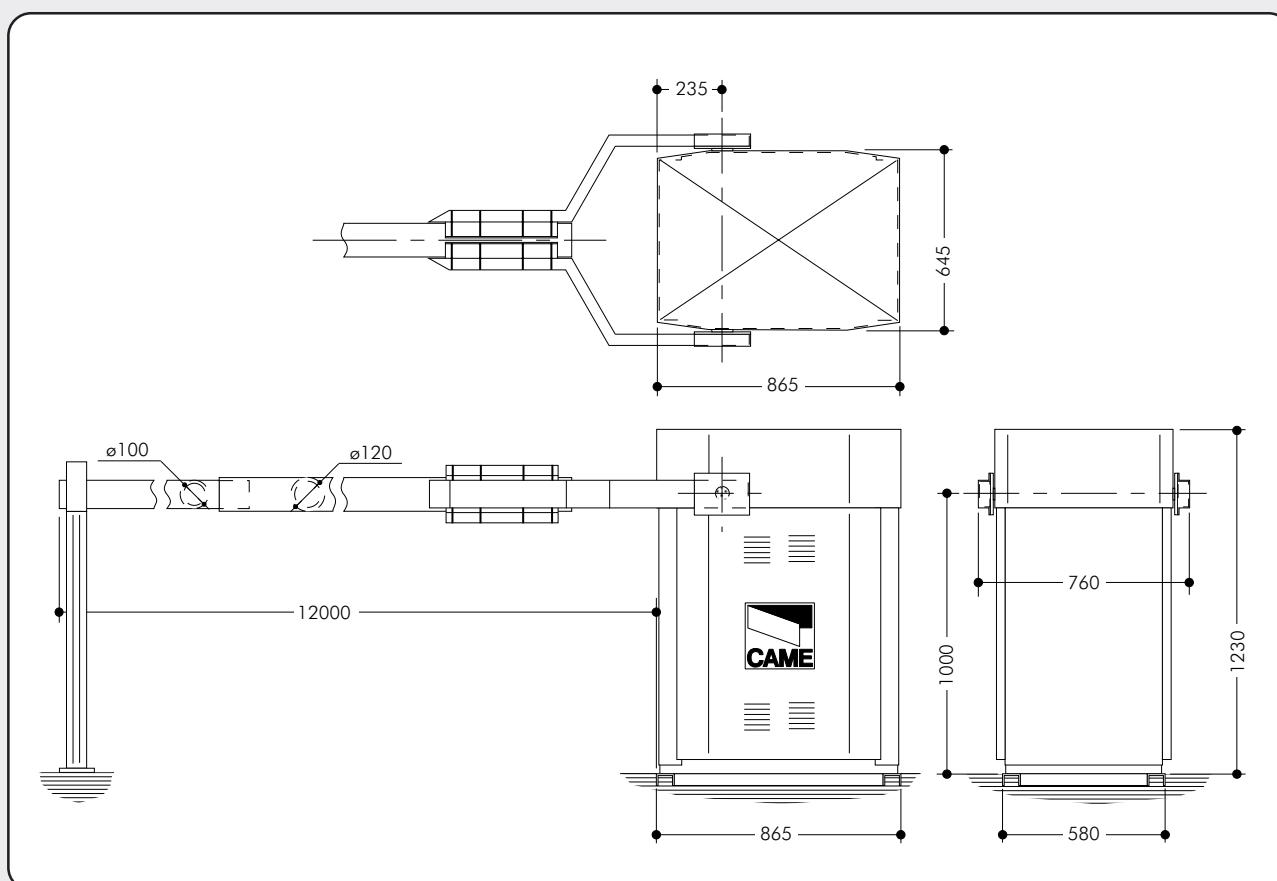

DESCRIPTION OF MAIN COMPONENTES

| | | |
|-----------|-----------------------------|---|
| 1 | REDUCTION GEAR UNIT | 24 VDC motors; non-reversible reduction gear with die-cast aluminium housing; uses worm gear reduction system which is permanently lubricated with liquid grease. |
| 2 | TRANSMISSION LEVERS | In forged, galvanised steel; adjustment rods in drawn hexagonal metal; self-lubricating joints. |
| 3 | ROTATION SHAFT | In C40 recycled steel, mounted on single-unit supports with terminal flanges for installation of barrier bar fork. |
| 4 | COUNTERWEIGHT SYSTEM | Uses 25 Kg rectangular plates which are assembled as needed. |
| 5 | RELEASE SYSTEM | Manual, with PVC handle and cord in self-lubricating sheath; safety lock. |
| 6 | HOUSING | Load-bearing structure in steel profiles, and external cover in press-bent 25/10 sheet steel. Both are galvanised and painted RAL 2004 orange. |
| 7 | MOUNTING BASE | U-profile in galvanised steel, complete with anchor stays and bolts for attachment of housing structure. |
| 8 | BARRIER BAR FORK | In galvanised steel painted RAL 9005 black; supplied in two symmetrical parts which are ready for assembly. |
| 9 | BARRIER BAR | In 6060 TA16 aluminium alloy painted RAL 9010 white; supplied in two circular sections (Ø120 and Ø100 mm) which are assembled to the desired size. |
| 10 | CONTROL PANEL | Housing in ABS with IP54 level of protection, installed in horizontal position. |

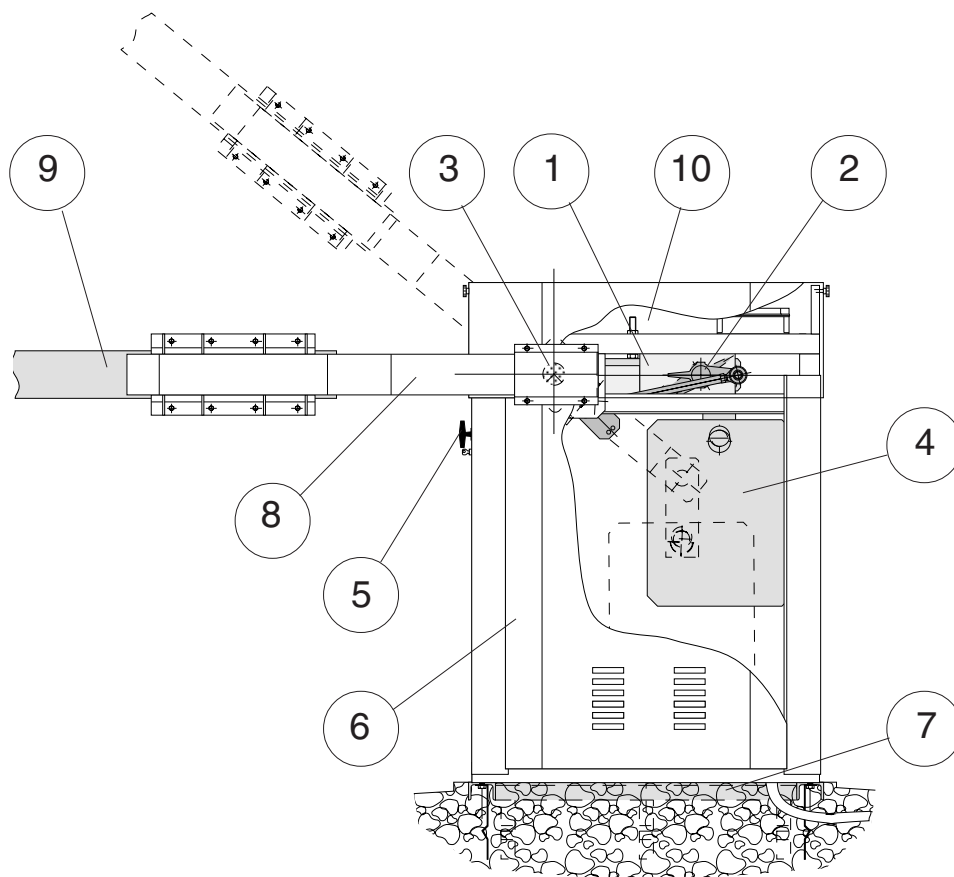

DESCRIPTION OF ASSEMBLY PROCEDURE

1 - ASSEMBLY OF FIXED STRUCTURES, MARKING

a) determine the desired positions for the housing as well as for the fixed support for the barrier bar; mark the longitudinal and transverse axes of the barrier.

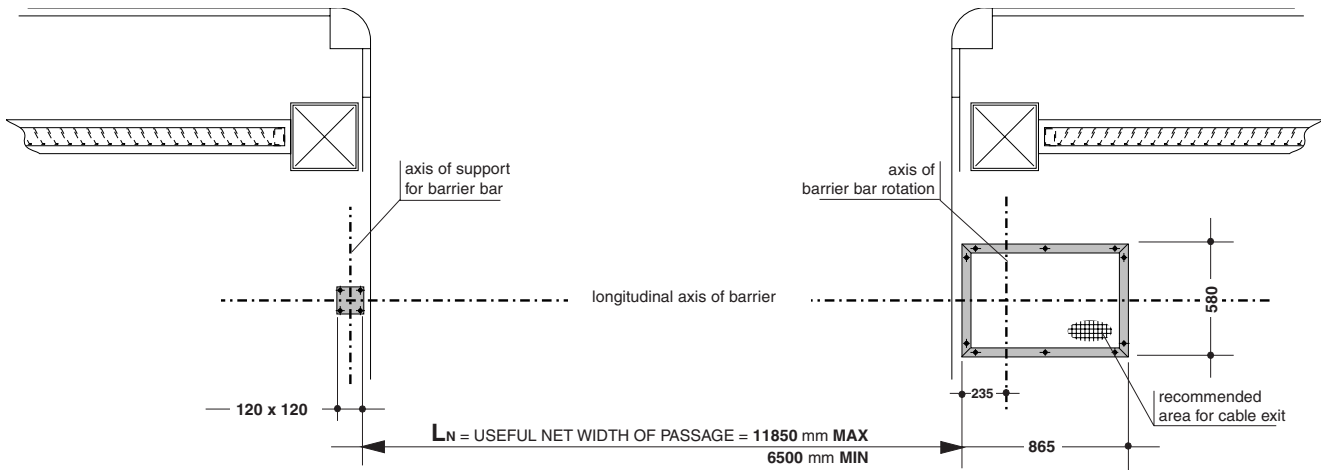

b) detach the mounting base from the housing and mount the anchor stays on the base; apply grease and/or removable tape to protect the threaded bolts protruding from the top.

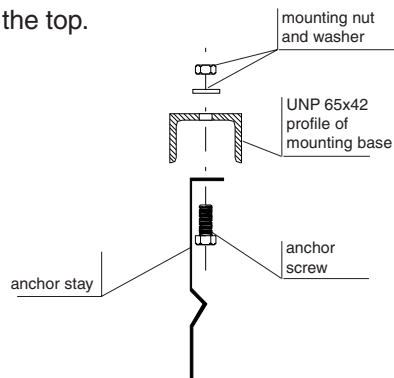

c) Sink everything into the relative cement bases. Be sure that the mounting base is perfectly level, and that the electrical cables for the unit protrude in the area indicated.

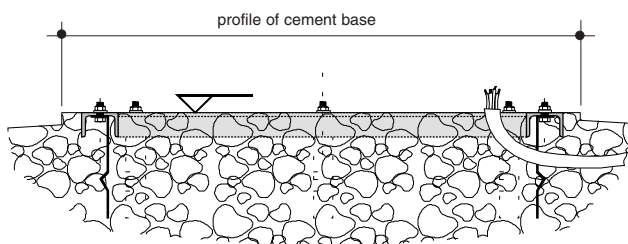

DESCRIPTION OF ASSEMBLY PROCEDURE

2 - PRELIMINARY ASSEMBLY OF THE BARRIER BAR

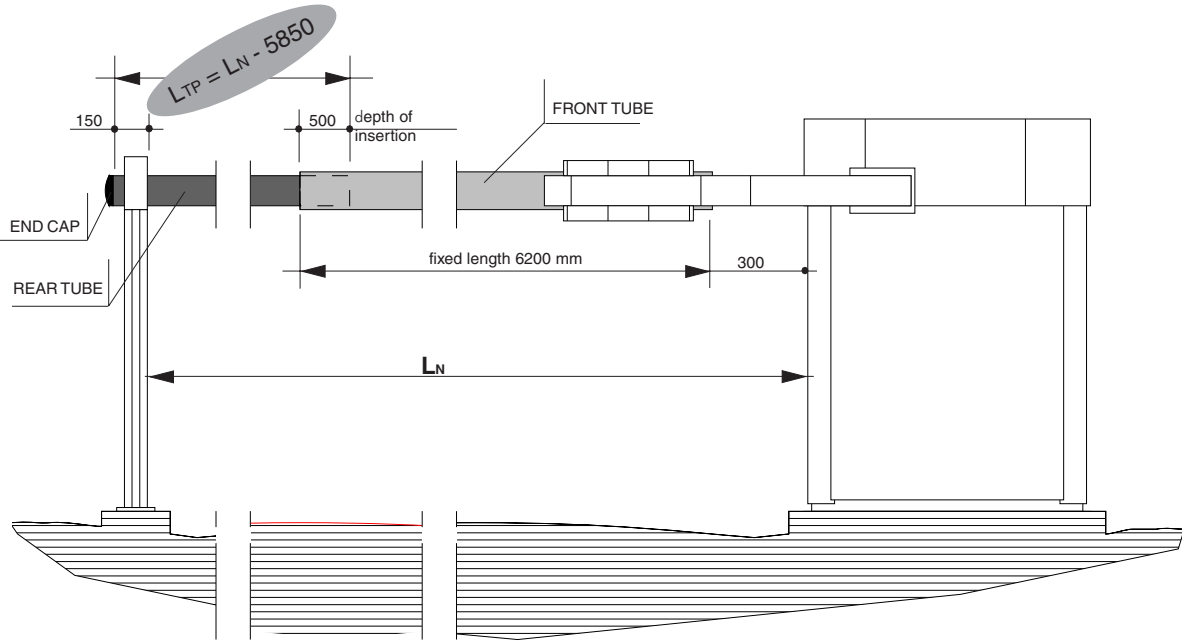

a) use the indicated formula to determine length L_{TP} of the rear tube ($\text{Ø}100$ mm), cut the tube to the correct length and install the end cap.

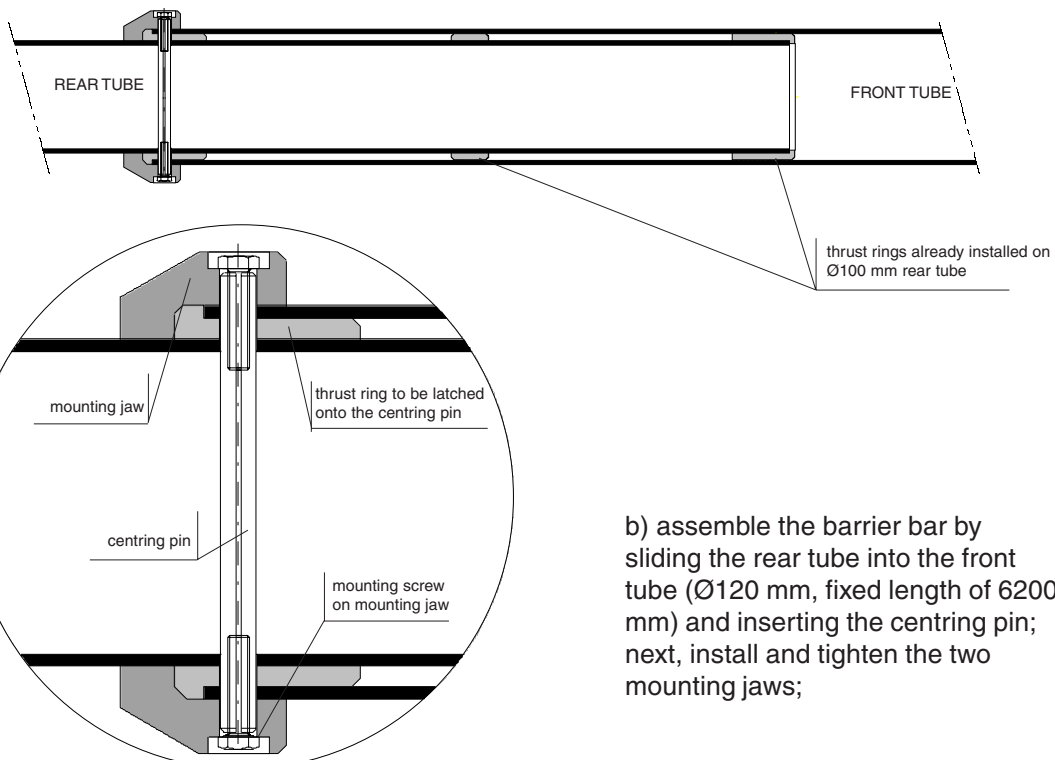

b) assemble the barrier bar by sliding the rear tube into the front tube ($\text{Ø}120$ mm, fixed length of 6200 mm) and inserting the centring pin; next, install and tighten the two mounting jaws;

3 - INSTALLING THE BARRIER

a) remove the cover of the housing (by lifting) and remove the sides of the housing (by raising and withdrawing them from below); clean the cement bases and free the bolts on the anchor stays by removing the protection tape and nuts;

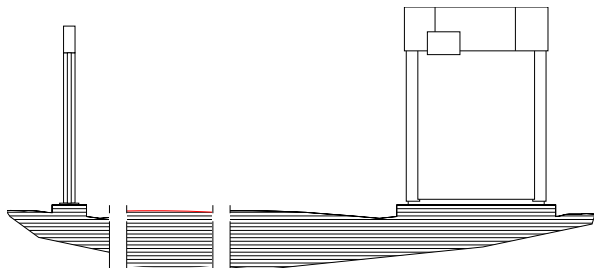

b) position and mount the housing on the mounting base;

c) position and mount the fixed support for the barrier bar, and make sure it is in perfect longitudinal alignment with the housing;

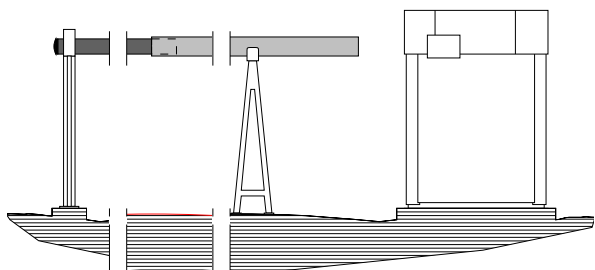

d) with the aid of a stand and the fixed support, place the barrier bar at the approximate height and axis of operation;

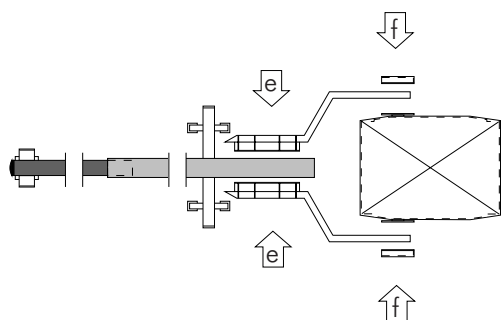

e) install the fork and unite the two mounting jaws on the barrier bar, but do not tighten the bolts;

f) next, mount the barrier bar on the terminal plates of the rotation shaft, but do not tighten the bolts;

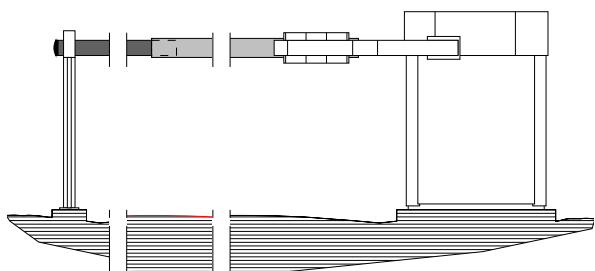

g) check for misalignment and adjust if necessary; then, firmly tighten the bar onto the fork and firmly tighten the fork onto the housing.

a) install the release handle, turn the safety key and rotate the handle to release the gear motors;

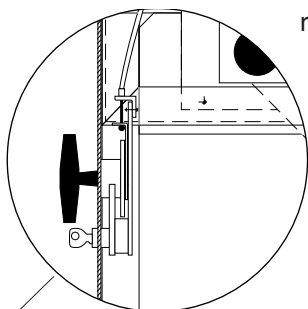

b) insert the counterweight plates on the support, alternatively on the left and right, until the bar shows signs of raising. **N.B.:** if not all the counterweight plates are used, they must be fixed with a hose clamp, to avoid possible release during movement.

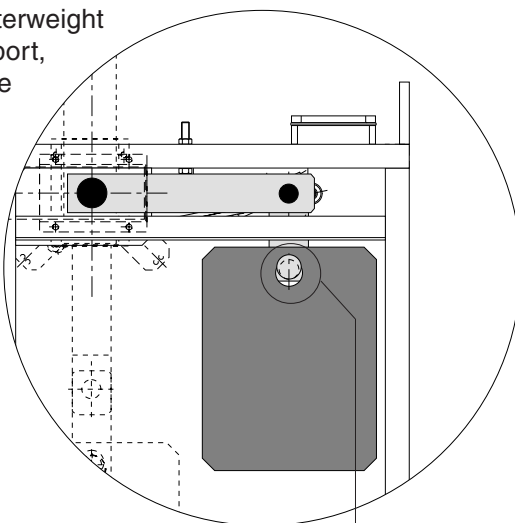

c) balance the bar so that it stays in position when it is manually placed at a 45° angle;

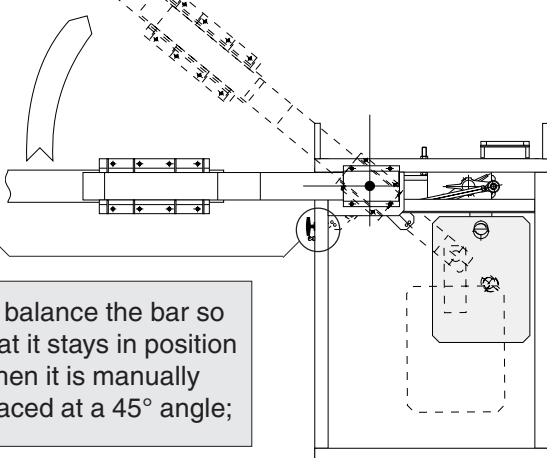

Hose clamp

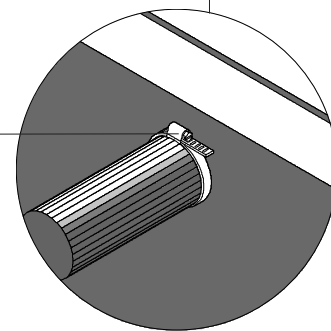

d) adjust the vertical mechanical stop by fixing the angle of the open barrier bar so that it does not exceed 90°;

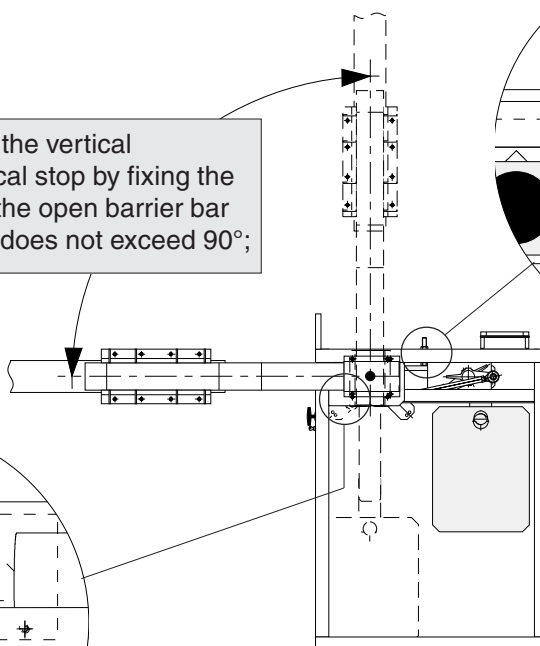

e) adjust the horizontal mechanical stop when the barrier bar is in the lowered position;

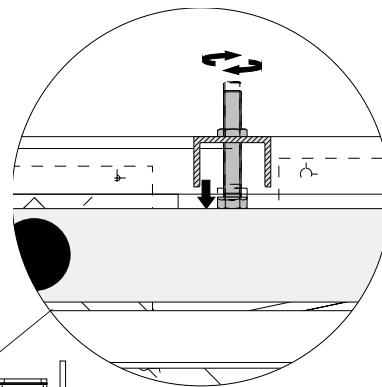
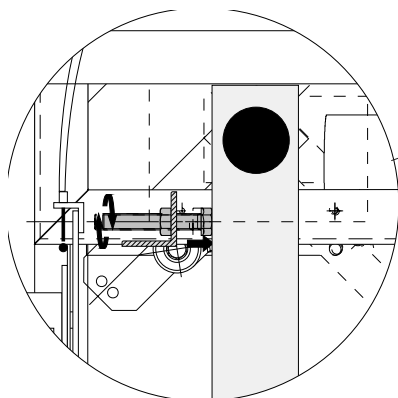

ZL37B CONTROL PANEL

DESCRIPTION & CONTROL LOGIC

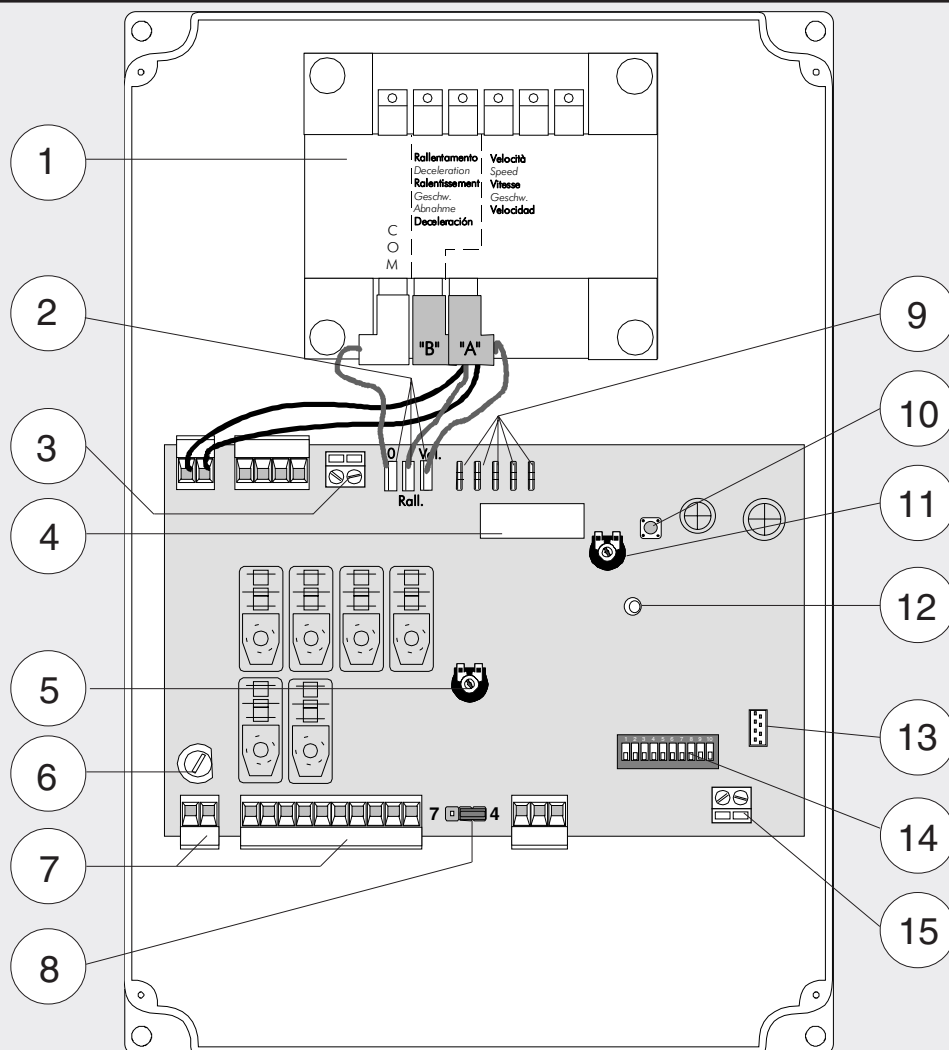

MAIN COMPONENTS

- 1) Transformer
- 2) Connectors for power supply motor
- 3) Terminal block for motor connections
- 4) 2A accessories fuse
- 5) Amperometric sensitivity adjustment (trimmer SENS)
- 6) 3,15A line fuse
- 7) Terminal block for external connections
- 8) Jumper for selection of type of control for button in 2-7
- 9) Connectors for connection to battery charger LB35
- 10) Button for memorizing code numbers
- 11) Automatic closing time adjustment (trimmer TCA)
- 12) Radio code / automatic closing signal LED
- 13) Radiofrequency board socket (see table pag. 11)
- 14) "Funcion selection" dip-switch
- 15) Terminal block for antenna connections

This control board is powered by 230V a.c. across terminals L1 and L2, and is protected by a 3.15A fuse on the main power line. Control systems are (24) powered by low voltage and protected with by a 2A fuse. The total power consumption of 24V accessories must not exceed 40 W.

Safety

Photocells can be connected to obtain:

- a) Re-opening during the closing cycle;
 - b) Total stop: the movement of the bar is interrupted, and the automatic closure cycle is deactivated. Use the keyboard or the radio transmitter to resume movement of the bar;
 - c) Immediate closure (the bar is lowered automatically after the vehicle has passed the safety devices, on the terminals 2-C5 of the control panel);
- Amperometric safety device: see NOTE;
 - Fixed operating time of 20 sec.

Accessories which can be connected to this unit

- LB35 board, used to power the automation system using battery power in case of a power failure. When the power supply is restored, the batteries are recharged automatically (refer to instruction sheet);
- Flashing signal light when bar is in motion;
- Plug-in radio receiver.

Other functions available

- Automatic closing: The automatic closing timer is automatically activated at the end of the opening cycle. The preset, adjustable automatic closing time is automatically interrupted by the activation of any safety system, and is deactivated after a total stop command or in case of power failure;
- Obstacle detection: When the motor is stopped (bar is closed, open or half-open after an emergency stop command), the transmitter and the control pushbutton will be deactivated if an obstacle is detected by one of the

safety devices (for example, the photocells);

- "Human presence" operation;
- Flashing light activated before opening and closing cycle begins;
- Activation of a 24V output signal during the movement phases and in the closed position;
- "Slave" operation when two motors are used in combination (see page 15);
- Function that increases the braking action on the barrier;
- Selection of command sequence:
 - open-close-reverse;
 - open only.

Adjustments

- Trimmer TCA = Automatic closing time: 0" to 120";
- Trimmer SENS = Sensitivity of amperometric safety system: min/max.

Important: Shut off the mains power and disconnect the batteries before servicing the inside of the unit.

NOTA

When an obstacle is encountered, the amperometric locking device intervenes as follows:

- a) if in the aperture phase, the bar stops;
- b) if in the closure phase, the movement of the bar is reversed.

N.B.: In situation (b), if an obstacle is detected three times, the bar stops during aperture, and automatic closure is deactivated.

Use the keyboard or the radio transmitter to resume movement of the bar.

SELECTION FUNCTION

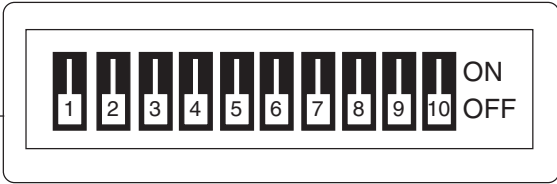
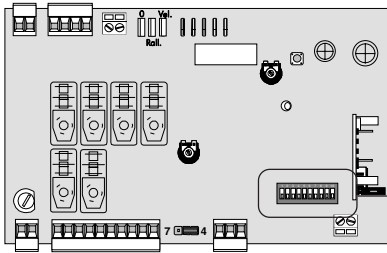

ON activated OFF deactivated

1 1 = function **automatic closure** **1**

- deactivated immediate closure (8 ON)

ON activated OFF deactivated

2 2 = function **"open only"** by radio remote control (when receiver is installed) **2**

ON deactivated OFF activated

2 2 = function **"open-close-inversion"** by radio remote control (when receiver is installed) **2**

ON activated OFF deactivated

3 3 = function **24V output during movement and in the closed position** **3**

ON deactivated OFF activated

3 3 = function **24V output during movement** **3**

ON activated OFF deactivated

4 4 = function **"human presence"** **4**

ON activated OFF deactivated

5 5 = function **flashing light en opening and closing** **5**

ON activated OFF deactivated

6 6 = function **obstacle detection** (with motor at end of travel) **6**

ON activated OFF deactivated

7 7 = function **slave** **7**

ON deactivated OFF activated

8 8 = function **immediate closure** **8**

- connect safety device across 2-C5;
- deactivate automatic closure (1 OFF)

ON deactivated OFF activated

9 9 = function **total stop** **9**

- connect safety device across 1-2

ON activated OFF deactivated

10 10 = function **increase braking action on barrier bar** **10**

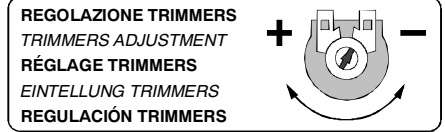
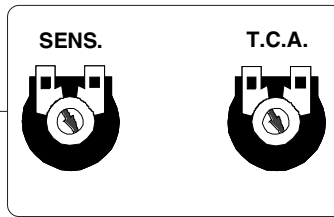
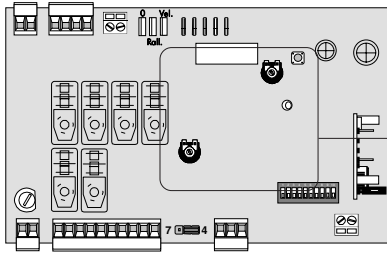

Trimmer SENS. = Adjustment of amperometric sensitivity min./max.

Trimmer T.C.A. = Adjustment automatic closing time from a minimum of 0 seconds to a maximum of 120 seconds.

PROGRAMMING THE REMOTE CONTROL

PROCEDURE

- A. insertan AF card **.
- B. encode transmitter/s.
- C. store code in the motherboard.

A

AF BOARD INSERTION

| Frequency / MHz | Radiofrequency board | Transmitter |
|-----------------|----------------------|-------------|
| FM 26.995 | AF130 | TFM |
| FM 30.900 | AF150 | |
| AM 26.995 | AF26 | TOP |
| AM 30.900 | AF30 | |
| AM 433.92 | AF43S / AF43SM | TAM / TOP |
| | AF43SR | ATOMO |

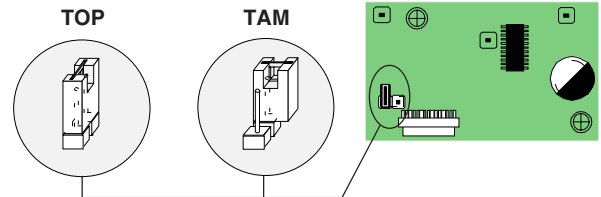

(**) On AM transmitters operating at 433.92 MHz (TOP and TAM series), position the jumper connection on circuit card AF43S as shown on the sheet.



The AF board should ALWAYS be inserted when the power is off because the motherboard only recognises it when it is powered.

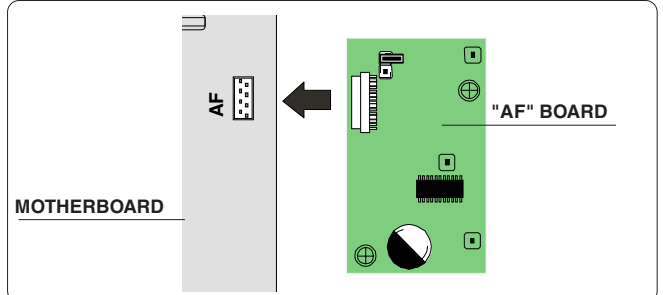

1) On one of the two control panels, set Dip 7 to **ON** in order to select the motor controlled externally (slave).

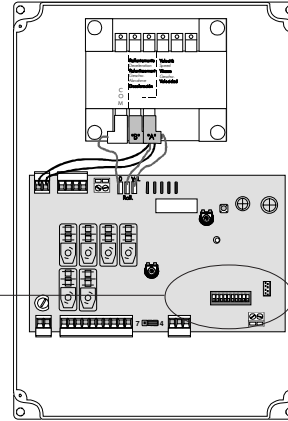
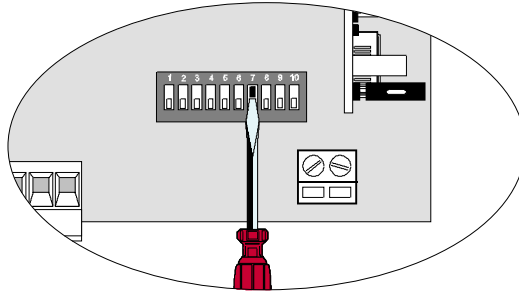

2) Wire the electrical connections only on the terminal board for the pilot motor in the normal.

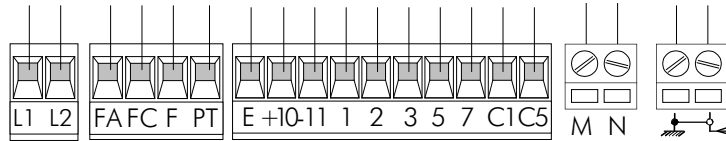

3) Connect the two control panels using the interlock terminals as shown in the figure.

